

Panasonic
ideas for life

**Lower output capacitance
and on resistance.
High speed switching.
(Turn on time: 0.2ms,
Turn off time: 0.08ms).**

**RF PhotoMOS
(AQV220N)**

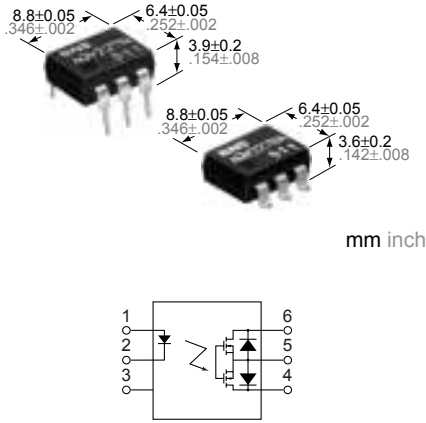

FEATURES

1. PhotoMOS relay with high response speed, low leakage current and low On resistance

2. Low capacitance between output terminals ensures high response speed:

The capacitance between output terminals is small, typically 10 pF. This enables for a fast operation speed of 200 μ s.

3. High sensitivity and low On resistance

Maximum 0.1 A of load current can be controlled with input current of 5 mA. The On resistance is less than our conventional models. With no metallic contacts, the PhotoMOS relay has stable switching characteristics.

4. Low-level off state leakage current
The SSR has an off state leakage current of several milliamperes, whereas the PhotoMOS relay has only 30 pA even with the rated load voltage of 200 V (AQV227N).

5. Controls low-level analog signals
PhotoMOS relay features extremely low closed-circuit offset voltages to enable control of small analog signals without distortion.

6. Low terminals electromotive force
(approx. 1 μ V)

TYPICAL APPLICATIONS

- Measuring devices
- Scanner, IC checker, Board tester

TYPES

Type	Output rating*		Part No.				Packing quantity	
			Through hole terminal	Surface-mount terminal			Tube	Tape and reel
	Load voltage	Load current	Tube packing style		Tape and reel packing style			
				Picked from the 1/2/3-pin side	Picked from the 4/5/6-pin side			
AC/DC type	200 V	70 mA	AQV227N	AQV227NA	AQV227NAX	AQV227NAZ	1 tube contains 50 pcs. 1 batch contains 500 pcs.	1,000 pcs.
	400 V	50 mA	AQV224N	AQV224NA	AQV224NAX	AQV224NAZ		

*Indicate the peak AC and DC values.

Note: For space reasons, the package type indicator "X" and "Z" are omitted from the seal.

RATING

1. Absolute maximum ratings (Ambient temperature: 25°C 77°F)

Item		Symbol	Type of connection	AQV227N(A)	AQV224N(A)	Remarks
Input	LED forward current	I_F		50 mA		
	LED reverse voltage	V_R		5 V		
	Peak forward current	I_{FP}		1 A		f = 100 Hz, Duty factor = 0.1%
	Power dissipation	P_{in}		75 mW		
Output	Load voltage (peak AC)	V_L		200 V	400 V	
	Continuous load current	I_L	A	0.07 A	0.05 A	A connection: Peak AC, DC
			B	0.08 A	0.06 A	B, C connection: DC
			C	0.10 A	0.08 A	
	Peak load current	I_{peak}		0.21 A	0.15 A	A connection: 100 ms (1 shot), $V_L = DC$
Power dissipation	P_{out}		360 mW			
Total power dissipation		P_T		410 mW		
I/O isolation voltage		V_{iso}		1,500 V AC		
Temperature limits	Operating	T_{opr}		-40°C to +85°C -40°F to +185°F		Non-condensing at low temperatures
	Storage	T_{stg}		-40°C to +100°C -40°F to +212°F		

RF PhotoMOS (AQV22○N)

2. Electrical characteristics (Ambient temperature: 25°C 77°F)

Item		Symbol	Type of connection	AQV227N(A)	AQV224N(A)	Remarks	
Input	LED operate current	Typical	I _{Fon}	0.90 mA		I _L = Max.	
		Maximum		3.0 mA			
	LED turn off current	Minimum	I _{Foff}	0.4 mA		I _L = Max.	
		Typical		0.85 mA			
	LED dropout voltage	Typical	V _F	1.25 V (1.14 V at I _F = 5 mA)		I _F = 50 mA	
		Maximum		1.5 V			
Output	On resistance	Typical	R _{on}	A	30 Ω	70 Ω	I _F = 5 mA I _L = Max. Within 1 s on time
		Maximum			50 Ω	100 Ω	
		Typical	R _{on}	B	16 Ω	55 Ω	
		Maximum			25 Ω	70 Ω	
	Typical	R _{on}	C	8 Ω	28 Ω	I _F = 5 mA I _L = Max. Within 1 s on time	
	Maximum			12.5 Ω	35 Ω		
	Output capacitance	Typical	C _{out}	10 pF		I _F = 0 V _B = 0 f = 1 MHz	
		Maximum		15 pF			
	Off state leakage current	Typical	I _{Leak}	30 pA		I _F = 0 V _L = Max.	
		Maximum		10 nA			
Transfer characteristics	Switching speed	Turn on time*	Typical	T _{on}	0.20 ms		I _F = 5 mA I _L = Max.
			Maximum		0.5 ms		
		Turn off time*	Typical	T _{off}	0.08 ms		I _F = 5 mA I _L = Max.
			Maximum		0.2 ms		
	I/O capacitance	Typical	C _{iso}	0.8 pF		f = 1 MHz V _B = 0	
		Maximum		1.5 pF			
Initial I/O isolation resistance	Minimum	R _{iso}	1,000 MΩ		500 V DC		

Note: Recommendable LED forward current I_F = 5mA.

*Turn on/Turn off time

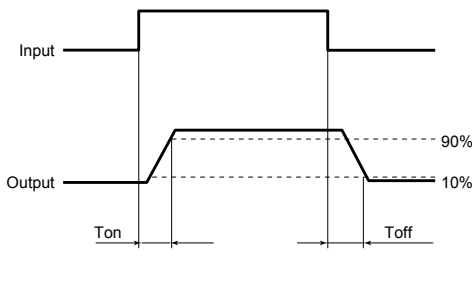

REFERENCE DATA

1. Load current vs. ambient temperature characteristics

Allowable ambient temperature: -40°C to +85°C
-40°F to +185°F

Type of connection: A

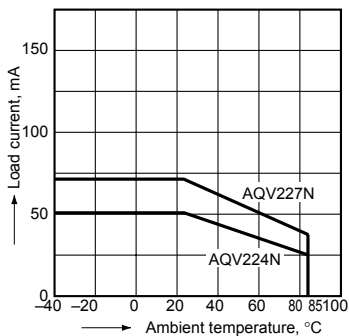

2. On resistance vs. ambient temperature characteristics

Measured portion: between terminals 4 and 6;
LED current: 5 mA; Load voltage: Max. (DC);
Continuous load current: Max. (DC)

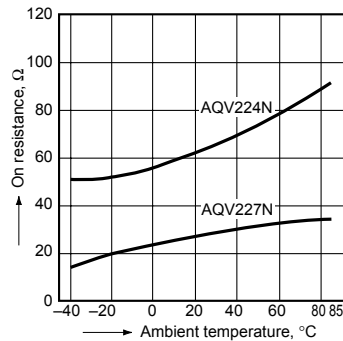

3. Turn on time vs. ambient temperature characteristics

Sample: AQV227N, AQV224N;
LED current: 5 mA; Load voltage: Max. (DC);
Continuous load current: Max. (DC)

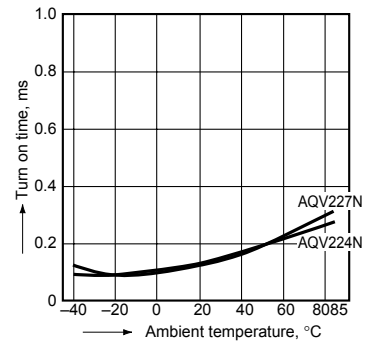

4. Turn off time vs. ambient temperature characteristics

Sample: AQV227N, AQV224N;
LED current: 5 mA; Load voltage: Max. (DC);
Continuous load current: Max. (DC)

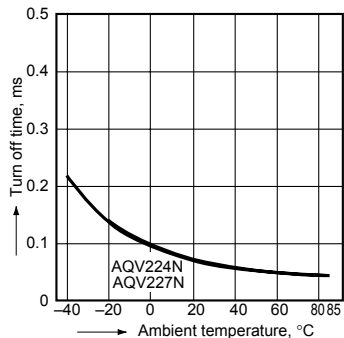

5. LED operate current vs. ambient temperature characteristics

Sample: AQV227N, AQV224N;
Load voltage: Max. (DC);
Continuous load current: Max. (DC)

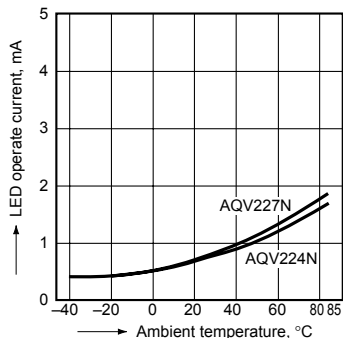

6. LED turn off current vs. ambient temperature characteristics

Sample: AQV227N, AQV224N;
Load voltage: Max. (DC);
Continuous load current: Max. (DC)

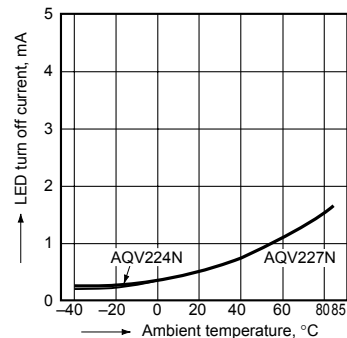

7. LED dropout voltage vs. ambient temperature characteristics

Sample: All types;
LED current: 5 to 50 mA

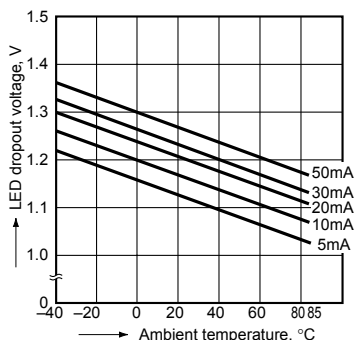

8. Current vs. voltage characteristics of output at MOS portion

Measured portion: between terminals 4 and 6;
Ambient temperature: 25°C 77°F

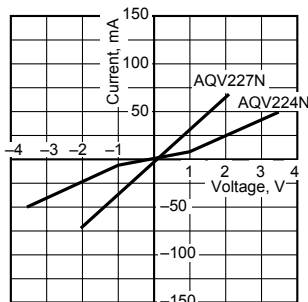

9. Off state leakage current

Sample: AQV227N, AQV224N;
Measured portion: between terminals 4 and 6;
Ambient temperature: 25°C 77°F

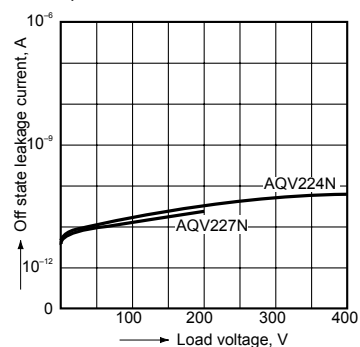

10. Turn on time vs. LED forward current characteristics

Sample: AQV227N, AQV224N;
Measured portion: between terminals 4 and 6;
Load voltage: Max. (DC);
Continuous load current: Max. (DC);
Ambient temperature: 25°C 77°F

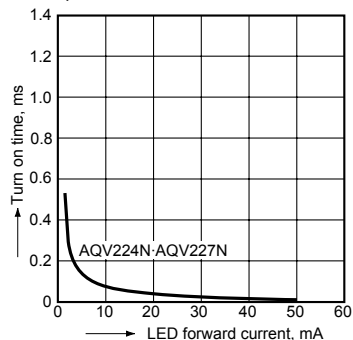

11. Turn off time vs. LED forward current characteristics

Sample: AQV227N, AQV224N;
Measured portion: between terminals 4 and 6;
Load voltage: Max. (DC);
Continuous load current: Max. (DC);
Ambient temperature: 25°C 77°F

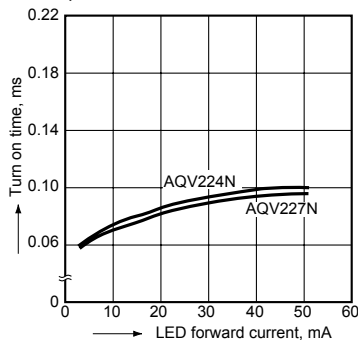

12. Output capacitance vs. applied voltage characteristics

Measured portion: between terminals 4 and 6;
Frequency: 1 MHz, 30 mVrms;
Ambient temperature: 25°C 77°F

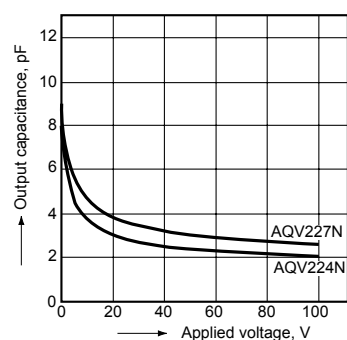

13. Isolation characteristics (50 Ω impedance)

Measured portion: between terminals 4 and 6;
Ambient temperature: 25°C 77°F

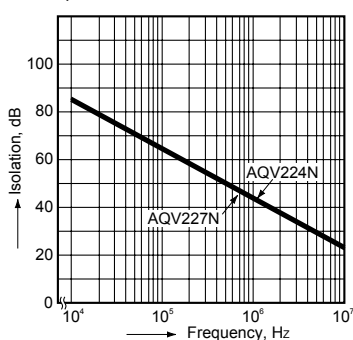

14. Insertion loss characteristics (50 Ω impedance)

Measured portion: between terminals 4 and 6;
Ambient temperature: 25°C 77°F

